



Doc. No.	NDP 033M-20
----------	-------------

MAINTENANCE MANUAL

YAMADA AIR-OPERATED DOUBLE DIAPHRAGM PUMP

DP-5F series
DP-10F series
DP-20F series
DP-25F series
DP-38F series

WARNING



- For your own safety, be sure to read these procedures carefully before performing maintenance on this product. After reading this document, be sure to keep it handy for future reference.

This maintenance manual covers what you should know about maintenance of the Yamada DP-F series Diaphragm Pumps.

This edition is based on the standards for the July 2022 production run. Remember, the specifications are always subject to change; therefore, some of the information in this edition may not apply to new specifications.

·Warnings and Cautions

For safe use of this product, be sure to note the following: In this document, warnings and cautions are indicated by symbols. These symbols are for those who will operate this product and for those who will be nearby, for safe operation and for prevention of personal injury and property damage. The following warning and caution symbols have the meanings described below. Be sure to remember their meanings.



WARNING : If you ignore the warning described and operate the product in an improper manner, there is danger of serious bodily injury or death.



CAUTION : If you ignore the caution described and operate the product in an improper manner, there is danger of personal injury or property damage.

Furthermore, to indicate the type of danger and damage, the following symbols are also used along with those mentioned above:



This symbol indicates a DON'T, and will be accompanied by an explanation on something you must not do.



This symbol indicates a DO, and will be accompanied by instructions on something you must do in a certain situation.

WARNING



- Before starting maintenance work, cut off the feed air and clean the pump. If air pressure or residue remain in the pump, there is danger of explosion, or possible poisoning resulting in serious injury or death if chemicals adhere to the skin or are accidentally swallowed. (For details on cleaning the pump, refer to Chapter 6 of the Operation Manual.)



- When replacing parts, be sure to use the recommended genuine parts or Equivalents. Use of other parts may cause a malfunction of the product. (Refer to Parts List the separate sheets.)

CAUTION



- When it is instructed that special tools must be used, be sure to use the specified tools. Otherwise, the pump may be damaged.



- Refer to "10.1 Specifications" in the Operation Manual. Also, remember that the pump is heavy, and extreme care must be taken when lifting it.

Table of Contents

·Warnings and Cautions	
·Table of Contents	
1.Principles of operation	1
2.Maintenance and Tools	
2.1 Maintenance	1
2.2 General tools	1
2.3 Special tools	2
2.4 Misc.	2
3.Ordering Replacement parts	2
4.Balls, Flat valves and Valve seats	
4.1 Removal	3
4.2 Inspection	
■ Ball valve types	4
■ Flat valve types	4
4.3 Installation	5
5.Diaphragm and Center rod	
5.1 Removal	
■ DP-5F	6
■ DP-10F, DP-20F, DP-25F, DP-38F	7
5.2 Inspection	8
5.3 Installation	9
6.Pilot valve Assembly and Bushing	
6.1 Removal	
■ DP-5F	10
■ DP-10F, DP-20F, DP-25F, DP-38F	10
6.2 Inspection	10
6.3 Installation	10
7.C Spool valve Assembly and Sleeve Assembly	
7.1 Removal	
■ DP-5F, DP-10F, DP-20F	11
■ DP-25F, DP-38F	11
7.2 Inspection	12
7.3 Installation	12
8. Instructions for applying lubrication	13
9. Retightening of Tie rods	13

1. Principles of operation

There are two diaphragms fixed to the center rod, one at each end. When compressed air is supplied to air chamber b (right side, see Fig.1.1), the center rod moves to the right, the material in material chamber B is pushed out, and at the same time material is sucked into material chamber A.

When the center rod is moved full-stroke to the right, the air switch valve is switched, compressed air is sent to air chamber a (left side, see Fig.1.2), and the center rod moves to the left. The material in material chamber A is pushed out, and at the same time material is sucked into material chamber B.

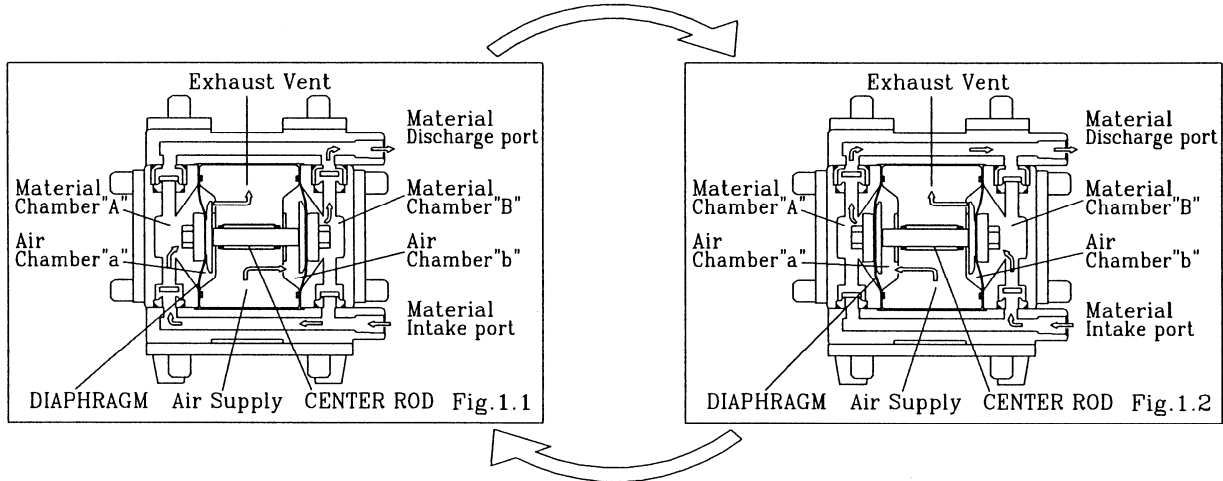

2. Maintenance and Tools

2.1 Maintenance

Since APDD (air powered double diaphragm pumps) can be used in many different applications varying in pressure, temperature, viscosity corrosiveness, and other properties, it is best to do a periodic inspection of the pump. Recording data on each installed pump during inspections will also serve as a record for any future maintenance. Typical maintenance involves inspection of the air valve, diaphragms, balls, valve seats and O-rings. BOTH diaphragms should be replaced if they show any sign of wear, abrading, or cracking. Refer to this manual for acceptable measurable working tolerances on other wearing components.

2.2 General tools

Tool name	Socket wrench			Open-end wrench				Plyer	Adjustable angle wrench	Hexagon wrench
	10 mm	13 mm	17 mm	10 mm	13 mm	17 mm	27 mm			
Size										2 mm
DP-5F	○			○				○		
DP-10F	○	○		○	○			○		
DP-20F	○	○		○	○			○		
DP-25F		○	○		○	○			○	
DP-38F		○	○		○	○			○	

2.3 Special tools(sold separately)

·Pilot valve remover

Purpose: Remove the pilot valve and cap (except with the DP-5F)

·Sleeve remover

Purpose: For removing sleeves

· Cap and disk remover

Purpose: Removing the center disk and cap (DP-5F)

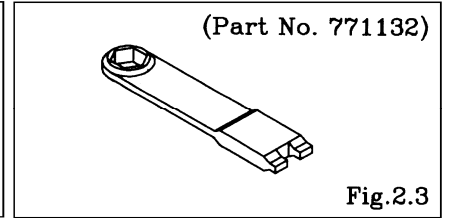
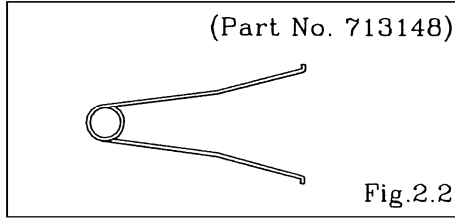
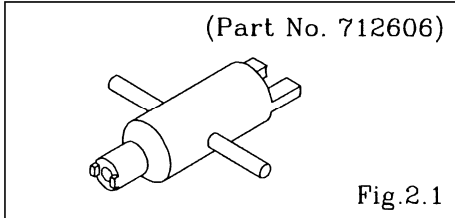

·PP wrench

Purpose: Removing the center disk (DP-10F, DP-20F, DP-25F, DP-38F)

· Torque wrench

Purpose: Retightening the center disk

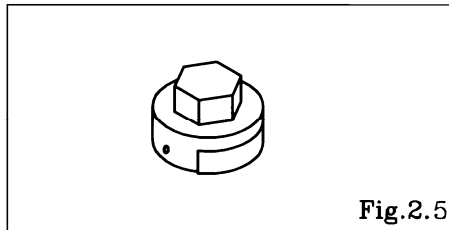
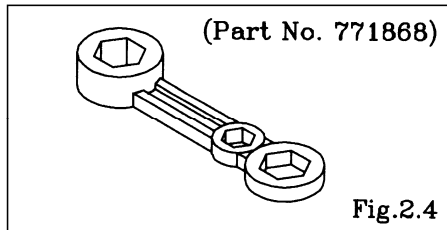

Part. No

804307 DP-5F

804308 DP-10F

804309 DP-20F

804310 DP-25F, DP-38F

2.4 Misc.

·Assembly lubricating oil

Fomblin® GR AR555 or equivalent

·Nuts

M6×1 (DP-5F), M8×1.25 (DP-10F)

M10×1.5 (DP-20F), M14×1.5 (DP-25F), M16×1.5 (DP-38F)

3. Ordering Replacement parts

For accurate and speedy shipment of parts, be sure to order the right parts for your model to distributor.

Indicate the parts numbers, descriptions, and quantities.

4. Balls, Flat valves and Valve seats

4.1 Removal

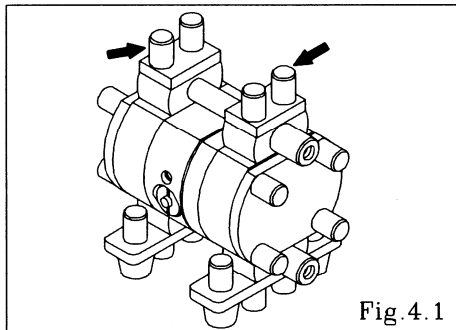

- Remove the 8 caps from the both sides of the upright tie rod. [Fig.4.1]

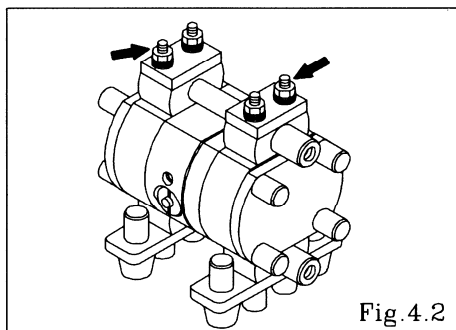

- Remove the 4 retainer nuts from the upper side of the upright tie rods, and remove the reinforcement plate, O ring (DP-25F, DP-38F) and out manifold. [Fig.4.2]

<NOTE>

- When the retainer nuts both sides of the upright tie rods remove, the in manifold removes.

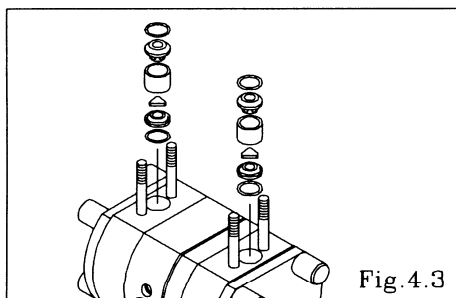

- Remove the O ring, valve stopper, valve guide, ball or flat valve and valve seat. [Fig.4.3]

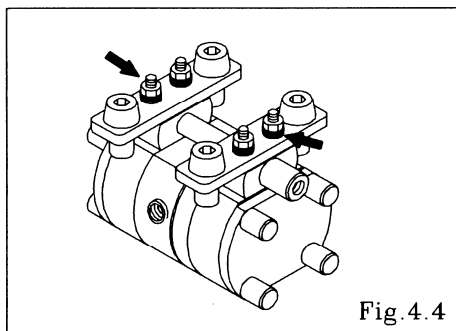

- Turn over the main body assembly. [Fig.4.4]
- Pull out the upright tie rods, and remove the base, O ring (DP-25F, DP-38F) and in manifold. [Fig.4.4]

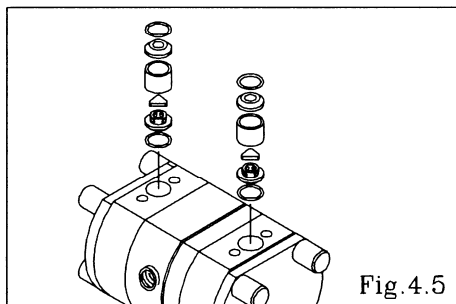

- Remove the O ring, valve seat, ball or flat valve, valve guide and valve stopper. [Fig.4.5]

4.2 Inspection

■ Ball valve types

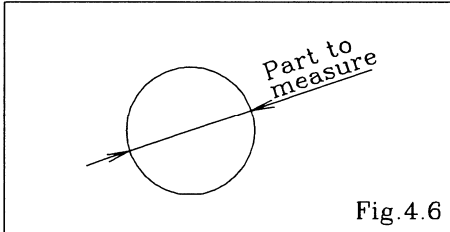

- Ball [Fig.4.6]

Measure the outside diameter, and if it is outside the usable range, replace the ball.

Usable range of Ball

DP-10F	Sø0.563 - Sø0.642 in {Sø14.3 - Sø16.3 mm}
DP-20F	Sø0.957 - Sø1.094 in {Sø24.3 - Sø27.8 mm}
DP-25F, DP-38F	Sø1.240 - Sø1.417 in {Sø31.5 - Sø36.0 mm}

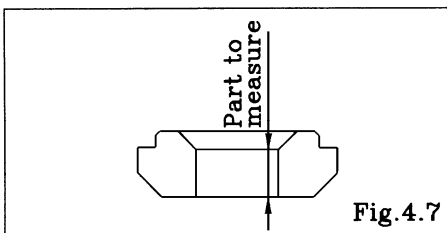

- Valve seat [Fig.4.7]

Measure the dimension shown at left, and if it is outside the usable range, replace the valve seat.

Usable range of Valve seat

DP-10F	0.094 - 0.236 in {2.4 - 6.0 mm}
DP-20F	0.110 - 0.276 in {2.8 - 7.0 mm}
DP-25F, DP-38F	0.126 - 0.295 in {3.2 - 7.5 mm}

■ Flat valve types

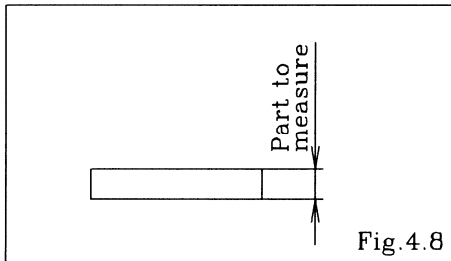

- Flat valve [Fig.4.8]

Measure the dimension shown at left, and if it is outside the usable range, replace the flat valve. If the flat valve is worn out or cracked, replace it.

Usable range of Flat valve

DP-5F	0.094 - 0.122 in {2.4 - 3.1 mm}
DP-10F	0.142 - 0.181 in {3.6 - 4.6 mm}
DP-20F	0.189 - 0.240 in {4.8 - 6.1 mm}
DP-25F, DP-38F	0.220 - 0.283 in {5.6 - 7.2 mm}

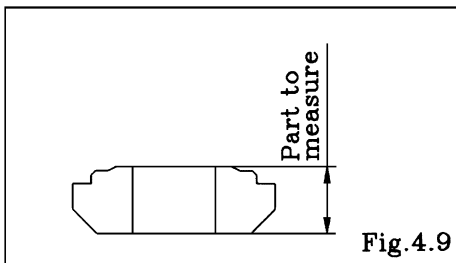

- Valve seat [Fig.4.9]

Measure the dimension shown at left, and if it is outside the usable range, replace the valve seat.

Usable range of Valve seat

DP-5F	0.228 - 0.283 in {5.8 - 7.2 mm}
DP-10F	0.268 - 0.323 in {6.8 - 8.2 mm}
DP-20F	0.323 - 0.402 in {8.2 - 10.2 mm}
DP-25F, DP-38F	0.378 - 0.480 in {9.6 - 12.2 mm}

4.3 Installation

For installation, see [Exploded View] on the separate sheet and install in the reverse order of disassembly.

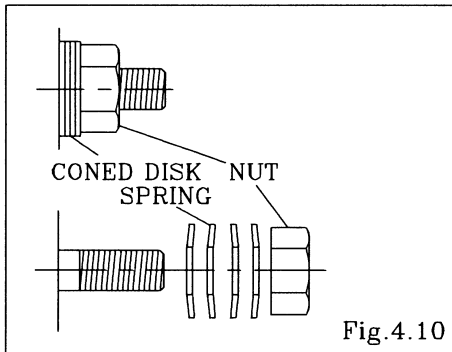

Tightening torque for vertical tie rods

DP-5F	45 in-lbf {5 N-m}
DP-10F	
DP-20F	
DP-25F	60 in-lbf {7 N-m}
DP-38F	135 in-lbf {15 N-m}

<NOTE>

- Make sure there is no dust on the seal surface and the seal is not damaged.
- Replace the PTFE O ring regardless of its condition.
- Make sure that direction the coned disk springs. [Fig.4.10]
- Retighten the tie rods before starting the pump. (See "8. Retightening of tie rods")

5. Diaphragm and Center rod

5.1 Removal

■ DP-5F

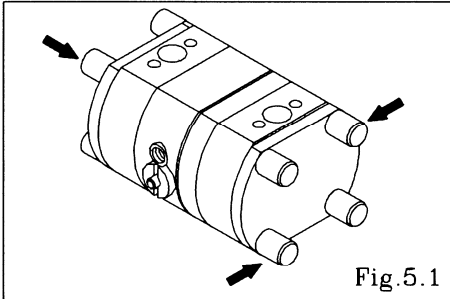

Fig.5.1

- Remove the ball, flat valve and valve seat etc. (see “4.1 Removal”)
- Remove the 8 caps from the both sides of horizontal tie rods. [Fig.5.1]

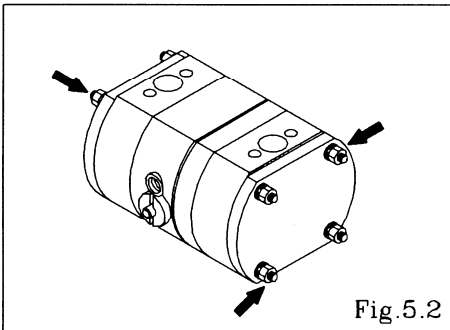

Fig.5.2

- Remove the 8 retainer nuts from the both sides of orizontal tie rods, and remove the reinforcement plate and out chamber.[Fig.5.2]

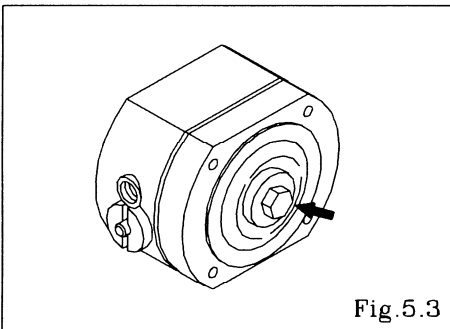

Fig.5.3

- Remove the center disk using the cap and disk remover. (special tool: Part No. 771132). [Fig.5.3]
- After the center disk (outside) has been removed, remove the diaphragm and the center disk (inside).
- Remove the center disk and center rod from the opposite side of the main body.

<NOTE>

- When the diaphragms are removed, the main body is separated 2 pieces. For easy work, leave the tie rods or bolts fastened temporarily before remove the diaphragms.

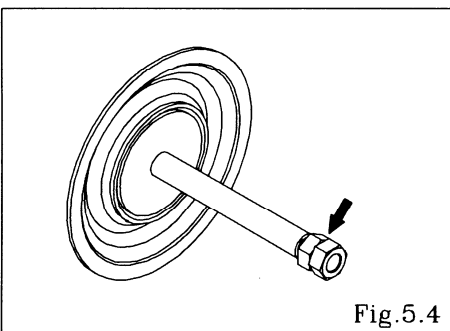
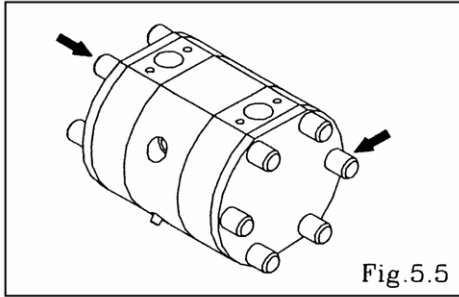

Fig.5.4

- Fix a double nut to one end of the center rod and take the diaphragm and center disk off the opposite end. [Fig.5.4]
Be careful not to scratch or score the center rod.

■ DP-10F, DP-20F, DP-25F, DP-38F



- Remove the ball or flat valve and valve seat etc. (see “4.1 Removal”)
- Remove the 12 (16 on DP-38F) caps from the both sides of the horizontal tie rods. [Fig.5.5]

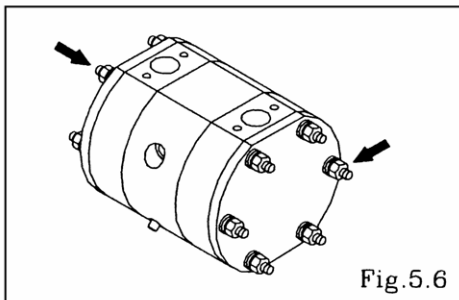

- Remove the 12 (16 on DP-38F) retainer nuts from the both sides of horizontal tie rods, and remove the reinforcement plate, O ring (DP-25F, DP-38F) and out chamber. [Fig.5.10]

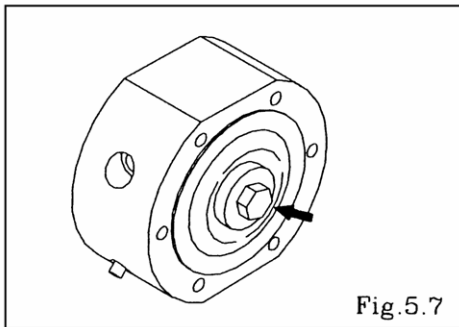

- Remove the center disk from one side using the PP wrench (special tool: Part No. 771868). [Fig.5.7]
- After the center disk (outside) has been removed, remove the diaphragm and the center disk (inside).
- Remove the center disk and center rod from the opposite side of the main body.

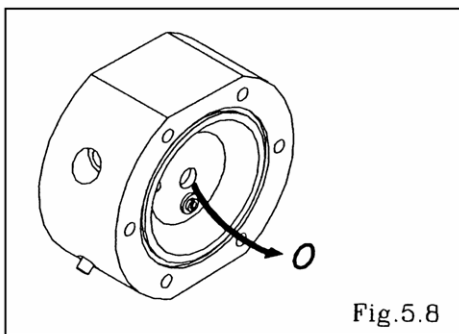

- Remove the packing from the body. [Fig.5.8]

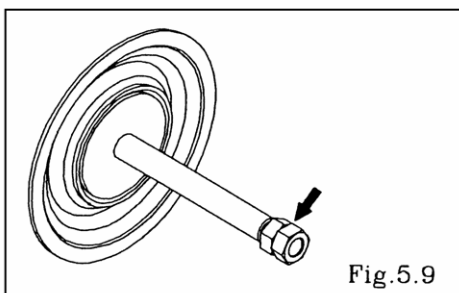

- Fix a double nut to one end of the center rod and take the diaphragm and center disk off the opposite end. [Fig.5.9] Be careful not to scratch or score the center rod.

5.2 Inspection

- Diaphragm

If the diaphragm is worn out or damaged, replace it.
Never replace just one diaphragm.

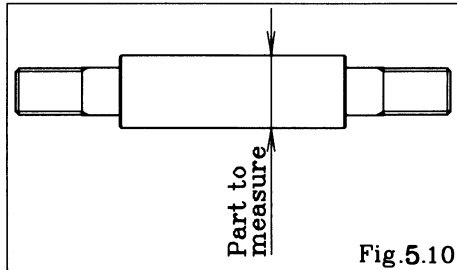

- Center rod [Fig.5.10]

Measure the diameter, and if it is outside the usable range, replace the center rod.

Usable range of center rod

DP-5F	$\varnothing 0.3917 - \varnothing 0.3937$ in { $\varnothing 9.95 - \varnothing 10.00$ mm}
DP-10F, DP-20F	$\varnothing 0.5492 - \varnothing 0.5512$ in { $\varnothing 13.95 - \varnothing 14.00$ mm}
DP-25F	$\varnothing 0.9429 - \varnothing 0.9449$ in { $\varnothing 23.95 - \varnothing 24.00$ mm}
DP-38F	$\varnothing 1.1752 - \varnothing 1.1792$ in { $\varnothing 29.85 - \varnothing 29.95$ mm}

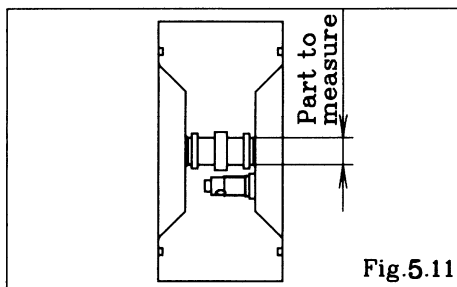

- Body [Fig.5.11]

Measure the inside diameter, and if it is outside the usable range, replace the body.

Usable range of body

DP-10F, DP-20F	$\varnothing 0.5524 - \varnothing 0.5551$ in { $\varnothing 14.03 - \varnothing 14.10$ mm}
DP-25F	$\varnothing 0.9449 - \varnothing 0.9489$ in { $\varnothing 24.00 - \varnothing 24.10$ mm}
DP-38F	$\varnothing 1.1811 - \varnothing 1.1851$ in { $\varnothing 30.00 - \varnothing 30.10$ mm}

- Packing

If the packing is worn out or cracked, replace it.

5.3 Installation

For installation, see [Exploded View] on the separate sheet and install in the reverse order of disassembly.

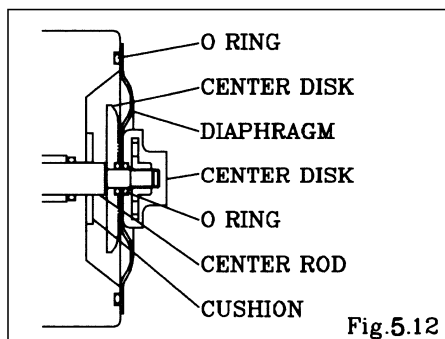

- Install the diaphragm with the convex side outside. [Fig.5.12]
- Insert the O ring.

Tightening torque for center rod

DP-5F	55 in-lbf {6 N-m}
DP-10F	140 in-lbf {16 N-m}
DP-20F	180 in-lbf {21 N-m}
DP-25F, DP-38F	400 in-lbf {45 N-m}

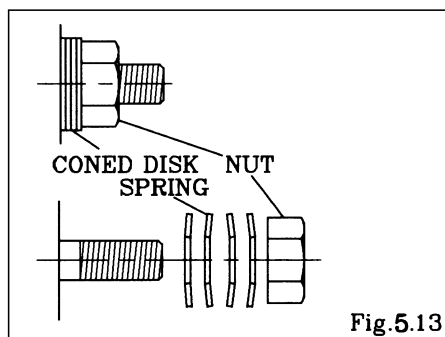

Tightening torque for Horizontal tie rods

DP-5F	45 in-lbf {5 N-m}
DP-10F, DP-20F	60 in-lbf {7 N-m}
DP-25F	80 in-lbf {10 N-m}
DP-38F	135 in-lbf {15 N-m}

<NOTE>

- Make sure there is no dust on the seal surface in order to prevent seal damaged.
- Tighten the bolts that balance should be equal from both side on diagonal line with even torque.
- Make sure that direction the coned disk springs. [Fig.5.13]
- Install the pilot valve, bushing and guide certainly. (DP-5F) (see "6.3 Installation")
- Retighten the tie rods before starting the pump. (See "8. Retightening of tie rods")

6. Pilot valve Assembly and Bushing

6.1 Removal

■ DP-5F

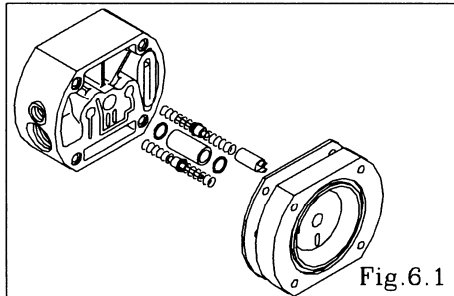

- Remove the diaphragm and center rod. (see “5.1 Removal”)
- Remove the body. [Fig.6.1]
- Draw out the pilot valve assembly. [Fig.6.1]
- Remove the O ring and bushing. [Fig.6.1]

■ DP-10F, DP-20F, DP-25F, DP-38F

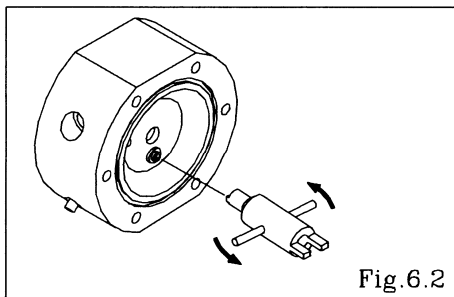

- Remove the diaphragm and center rod. (see “5.1 Removal”)
- Remove the valve seat using pilot the valve remover (special tool: Part No. 712606).
- Remove the O ring and pilot valve Assembly. [Fig.6.2]

6.2 Inspection

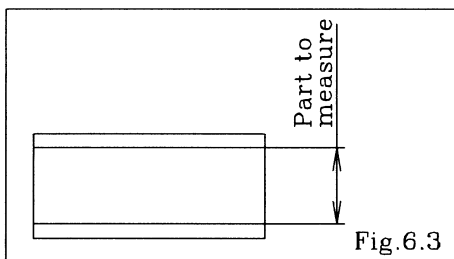

- Bushing (DP-5F) [Fig.6.3]
Measure the inside diameter, and if it is outside the usable range, replace the bushing.

Usable range of bushing	
DP-5F	$\phi 0.398 - \phi 0.406$ in $\{\phi 10.1 - \phi 10.3 \text{ mm}\}$

- O ring
If the O ring is worn out or cracked, replace it.
- Pilot valve assembly
If the pilot valve is worn out or cracked, replace it.

6.3 Installation

For installation, see [Exploded View] on the separate sheet and install in the reverse order of disassembly.

<NOTE>

- Make sure there is no dust on the seal surface and the seal is not damaged.
- Use the pilot valve remover (special tool: Part No. 712606).
- Retighten the tie rods before starting the pump.
(See “8. Retightening of tie rods”)

7. C Spool valve Assembly and Sleeve Assembly

7.1 Removal

■ DP-5F, DP-10F, DP-20F

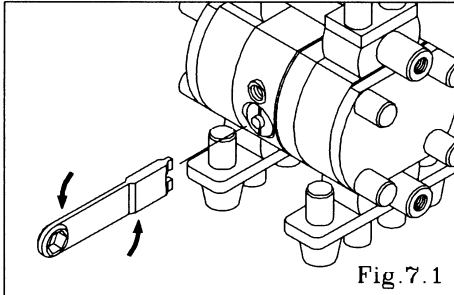

- Remove the cap using the cap and disk remover (special tool: Part No. 771132). (DP-5F) [Fig.7.1]
- Remove the cap using the pilot valve remover (special tool: Part No. 712606). (DP-10F, DP-20F) [Fig.7.1]

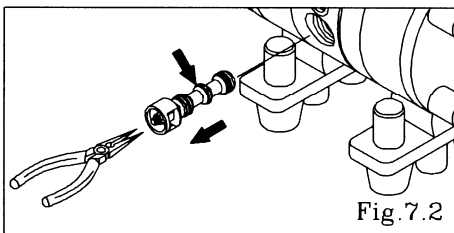

- Pull out the C spool valve assembly using the plier, and remove the seal ring from the C spool valve assembly. [Fig.7.2]

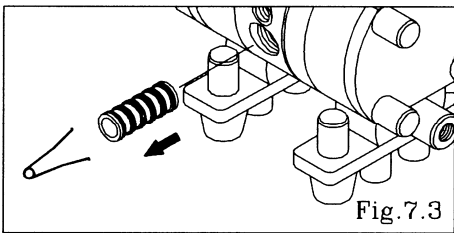

- Remove the sleeve using the sleeve remover (special tool: Part number 713148). [Fig.7.3]

■ DP-25F, DP-38F

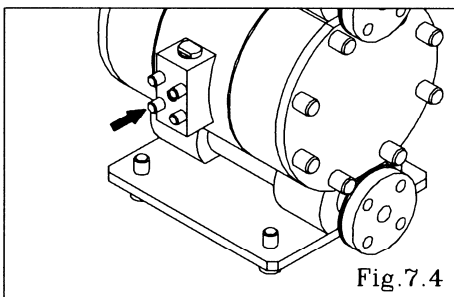

- Remove the 4 cap from the stud bolts. [Fig.7.4]

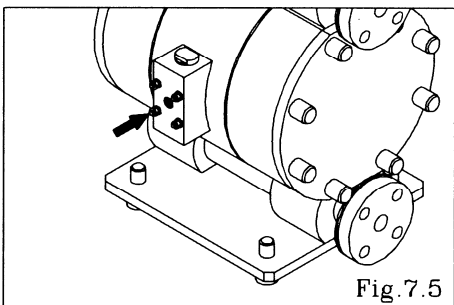

- Remove the 4 retainer nuts from the valve body, and remove the valve body. [Fig.7.5]

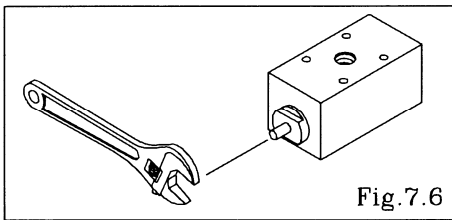

- Remove the caps both sides of valve body using the adjustable angle wrench, and remove the cushion. [Fig.7.6]

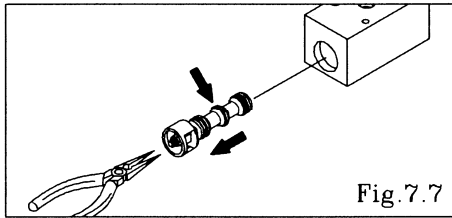

- Draw out the C spool valve assembly using the plyer, and remove the seal rings from the C spool valve assembly. [Fig.7.7]

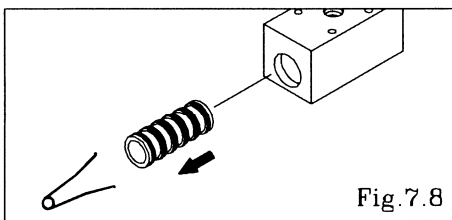

- Remove the sleeve from the valve body using the sleeve remover (special tool: Part No. 713148). [Fig.7.8]

7.2 Inspection

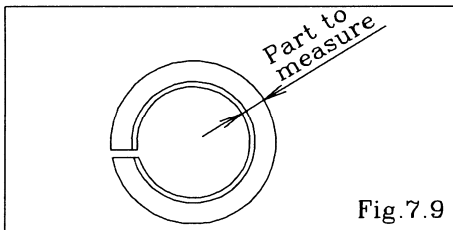

- C Spool Valve Assembly

Seal ring [Fig.7.9]

Measure the inside thick diameter, and if it is outside the usable range, replace the c spool valve assembly.

If the seal ring is worn out or cracked, replace c spool valve assembly.

Usable range of Seal ring

DP-5F	0.0551 - 0.0583 in {1.40 - 1.48 mm}
DP-10F, DP-20F	0.0716 - 0.0748 in {1.82 - 1.90 mm}
DP-25F, DP-38F	0.1004 - 0.1043 in {2.25 - 2.65 mm}

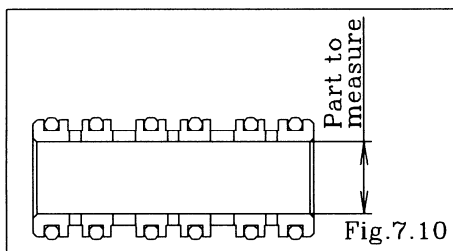

- Sleeve Assembly [Fig.7.10]

Measure the inside diameter, and if it is outside the usable range, replace the sleeve assembly.

Usable range of Sleeve

DP-5F	ø0.3740 - ø0.3760 in {ø9.50 - ø9.55 mm}
DP-10F, DP-20F DP-25F, DP-38F	ø0.6221 - ø0.6240 in {ø15.80 - ø15.85 mm}

- O ring

If the O ring is worn out or cracked, replace it.

<NOTE>

- C Spool valve Assembly and Sleeve Assembly should be replaced as a complete set.

7.3 Installation

For installation, see [Exploded View] on the separate sheet and install in the reverse order of disassembly.

Tightening torque for Valve body installation bolts

DP-25F, DP-38F	60 in-lbf {7 N-m}
----------------	-------------------

<NOTE>

- Make sure there is no dust on the seal surface and it is not damaged.
- Retighten the tie rods before starting the pump.
(See "8. Retightening of tie rods")

8. Instructions for applying lubrication

8.1 Applying lubricant to the Packing

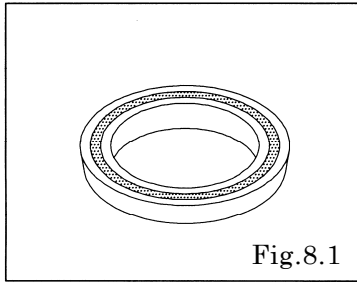

- Apply plenty of lubricant into the groove (V) of the packing. [Fig.8.1]
- <NOTE>
- Be careful that no aeration occurs when applying lubricants.

8.2 Applying Lubricant to the Center Rod

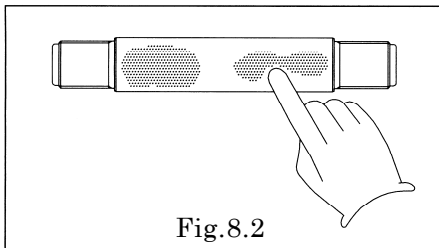

- Apply lubricant to the whole surface of center rod. [Fig.8.2]

8.3 Assemble

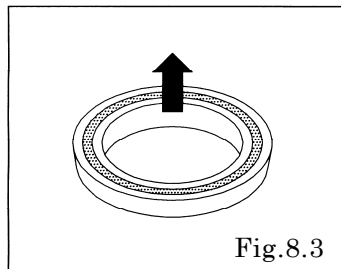

- The V Packing must be installed into body with the V facing out towards the air chambers. [Fig.8.3]
- <NOTE>
- In cases where the packing is installed incorrectly air leakage will occur.

9. Retightening of Tie rods

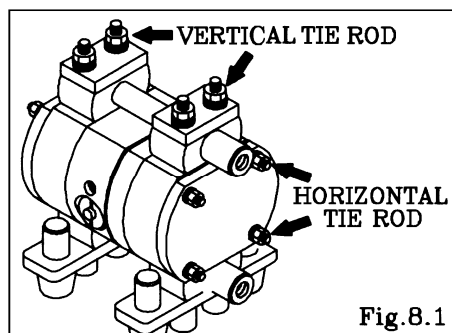

- The torque should be applied on the occasion of:
 - Right before the pump to use.
 - There are any leaks of material on daily inspecting a pump.

Retightening of tie rods and torque

	Horizontal tie rods	Vertical tie rods
DP-5F	35 in-lbf {4 N-m}	35 in-lbf {4 N-m}
DP-10F	55 in-lbf {6 N-m}	
DP-20F		70 in-lbf {8 N-m}
DP-25F	115 in-lbf {13 N-m}	115 in-lbf {13 N-m}

- <NOTE>
- Fasten the nut (tie rods) on a diagonal line alternately with even force.
 - Retighten the horizontal tie rods and then the vertical tie rods. [Fig.8.1] (Fig.8.1 shows the DP-5F.)

YAMADA AMERICA, INC

955 E. ALGONQUIN RD., ARLINGTON HEIGHTS, IL 60005, USA

PHONE : 1-847-631-9200 or 1-800-990-7867 (Toll Free)

FAX : 1-847-631-9273

E-mail : sales@yamadapump.com

Web : www.yamadapump.com

Manufactured by:

YAMADA CORPORATION

International Department

1-1-3, Minami-Magome, Ota ku, Tokyo, 143-8504, Japan

PHONE : +81-(0)3-3777-0241

FAX : +81-(0)3-3777-0584

E-mail : intl@yamadacorp.co.jp

Web : www.yamadacorp.co.jp